

Sample Gas Pump

P 2.3; P 2.83; P 2.4; P 2.84

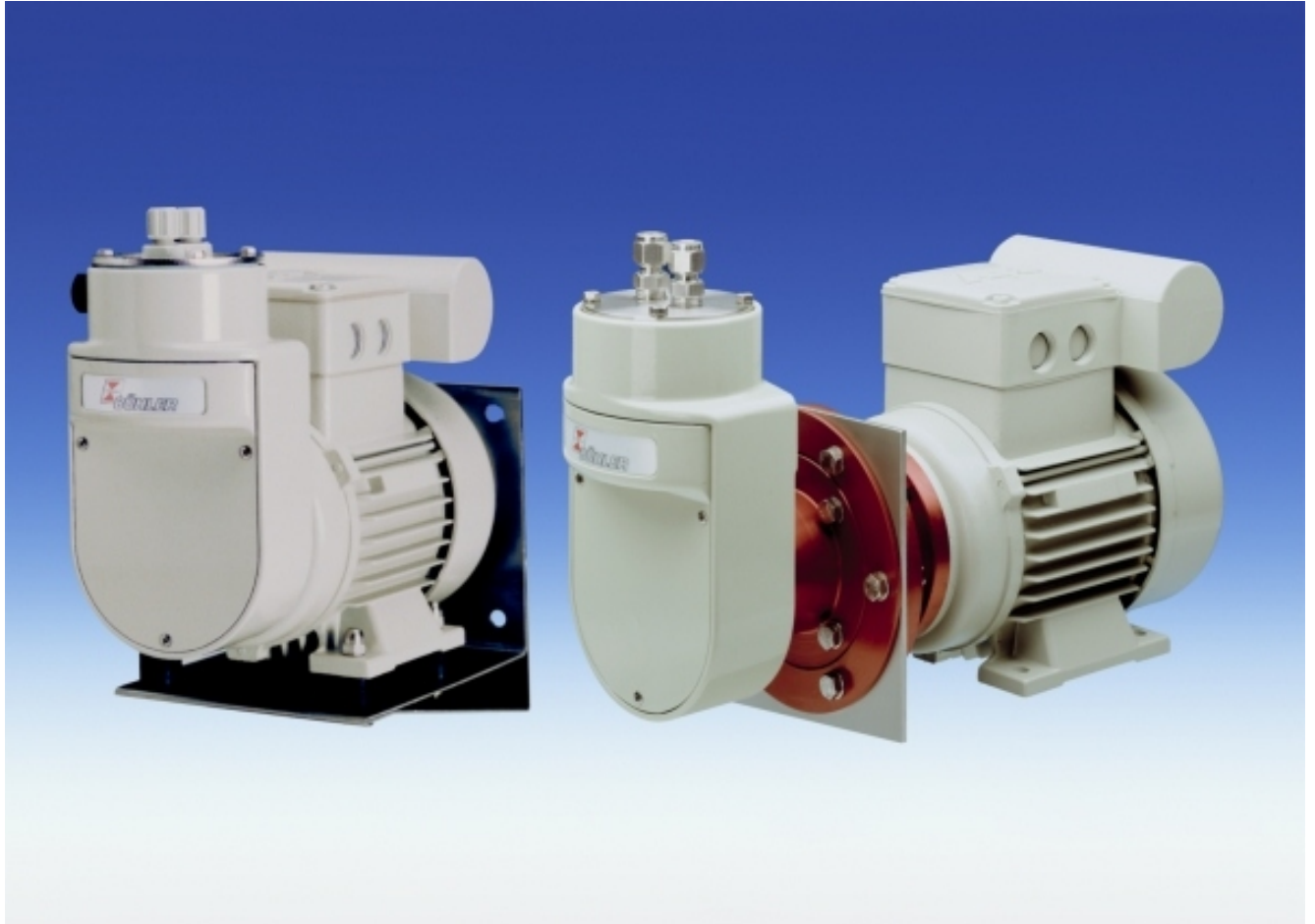

The transportation of sample gas in sample conditioning systems requires reliable sample pumps. The corrosive nature of the gas and the potential of condensate formation are the real challenges for any pump.

These sample pumps are equipped with a bellows made from solid PTFE. This design has demonstrated the highest reliability and long lifetime in numerous applications. Designed specifically for harsh gas applications that have entrained liquids present or where condensate is expected to form, it is recommended that the pump head be pointed downwards to accommodate draining of these liquids

A special flange design makes the P2.4 and P2.84 designs suitable for hot applications. The flange is designed in two parts one -carrying the pump head- is installed in a heated cabinet and the other -carrying the electrical motor- is flanged to the outside of the cabinet keeping the motor in ambient conditions.

- **Robust and reliable design**
- **Easy to replace valves**
- **Bellow made of one solid piece**
- **Pumps gases with entrained liquid**
- **Long life**
- **Explosion-proof version available**
- **Low noise**
- **115 V - models with CSA and FM approval**

Pump Models P2.3 and P2.83

For easy installation of the P2.3 and P2.83 pumps, a support console with vibration dampers is included.

The pump head can be ordered with an internal bypass valve.

The difference between the P2.3 and P2.83 pump is in the flow provided. The P2.3 pump has a capacity of 400 l/h free flow and the P2.83 has a capacity of 800 l/h free flow.

The P2.3 and P2.83 pumps must not be used in explosive areas. The corresponding type for ex areas would be the P2.2 ATEX, P2.2 AMEX and P2.82 AMEX, data sheet 420009, or the US-P2.6Ex, data sheet 420005.

Technical Data

| | | | | |
|------------------|------------------|---------------------|----------------------|---------------------|
| Nominal voltage | See order number | Media temperature | 100 °C | Valves: PTFE / PVDF |
| Nominal current | See order number | | 160 °C | Valves: PTFE / PEEK |
| Protection class | Electrical IP55 | Ambient temperature | max. 60 °C | |
| | Mechanical IP20 | CSA C-US(115V only) | CSA File No. 1703338 | |
| Weight | 6.5 kg | FM (115V only) | FM File No. 3038101 | |
| Dead space | 8.5 ml | | | |

Flow Curve P2.3

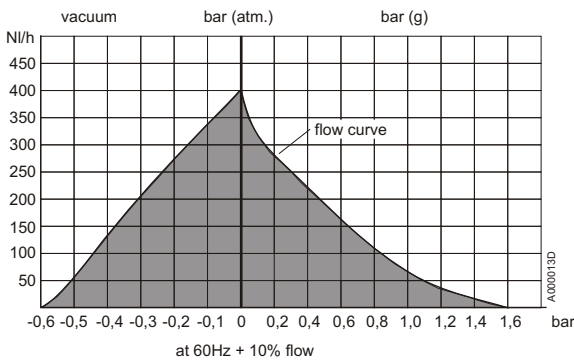

Flow Curve P2.83

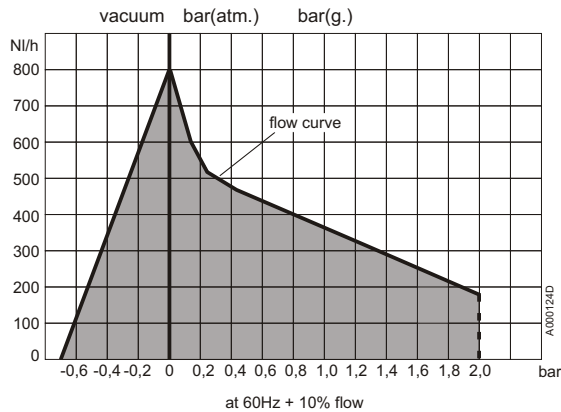

Please indicate with order

x stands for number below

The P2.83 pump is only available with 160°C valves.

Ordering example:

- part no.. 42 631112 99
- 63 for 800 Liter pump P2.83
- 1 for 230V 50/60Hz Motor
- 1 for pump head pointing up
- 1 pump head PTFE
- 2 for 160°C valves

Part no.

42 xx x x x x 99

56
63

P2.3 400l pump
P2.83 800l pump

Motor

230 V, 50/60Hz, 0.85/0.8 A
115 V, 50/60Hz, 1.7/1.6 A

Pump head position

Normal pos. vertical
Pointing downwards

Pump head material

PTFE
SS 1.4571, Viton, 1.4401
PTFE with bypass valve

Valves material

1 up to 100°C PTFE / PVDF (P2.3 only, not available for P2.83)
2 up to 160°C PTFE / PEEK

Pump Models P2.4 and P2.84

A cabinet wall thickness of up to 30mm (1.2") can be used without other modifications.

The difference between the P2.4 and P2.84 pump is in the flow provided. The P2.4 pump has a capacity of 400 l/h free flow and the P2.84 has a capacity of 800 l/h free flow.

The P2.4 and P2.84 Pumps must not be used in explosive areas. The corresponding type for ex areas would be the P2.4 ATEX, P2.4 AMEX and P2.84 AMEX, data sheet 420009.

Technical Data

| | | | | |
|------------------|------------------|----------------------|----------------------|--------------------|
| Nominal voltage | See order number | Media temperature | 160 °C | Valve: PTFE / PEEK |
| Nominal current | See order number | Ambient temp. | | |
| Protection class | Electrical IP55 | Motor | max. 60 °C | |
| | Mechanical IP20 | Pump head | max. 100 °C | |
| Weight (approx.) | 7.5 kg | CSA C-US (115V only) | CSA File No. 1703338 | |
| Dead space | 8.5 ml | FM (115V only) | FM File No. 3038101 | |

Flow Curve P2.4

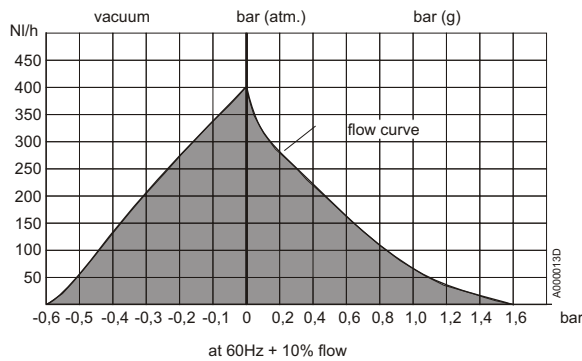

Flow Curve P2.84

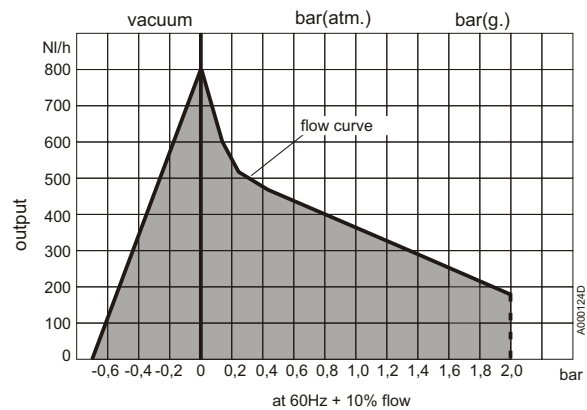

Please indicate with order

x stands for the number indicated below

Part no. 42

| | | | | |
|----|---|---|---|---|
| xx | x | 1 | x | 2 |
|----|---|---|---|---|

 99

| |
|----|
| 57 |
| 64 |

P2.4 400 l/h pump
P2.84 800 l/h pump

Motor

230 V, 50/60Hz, 0.85/0.8 A
115 V, 50/60Hz, 1.7/1.6 A

| |
|---|
| 1 |
| 2 |

Pump head material

PTFE
SS 1.4571, Viton, 1.4401

| |
|---|
| 1 |
| 2 |

Dimensions P2.3 and P2.83 Pumps

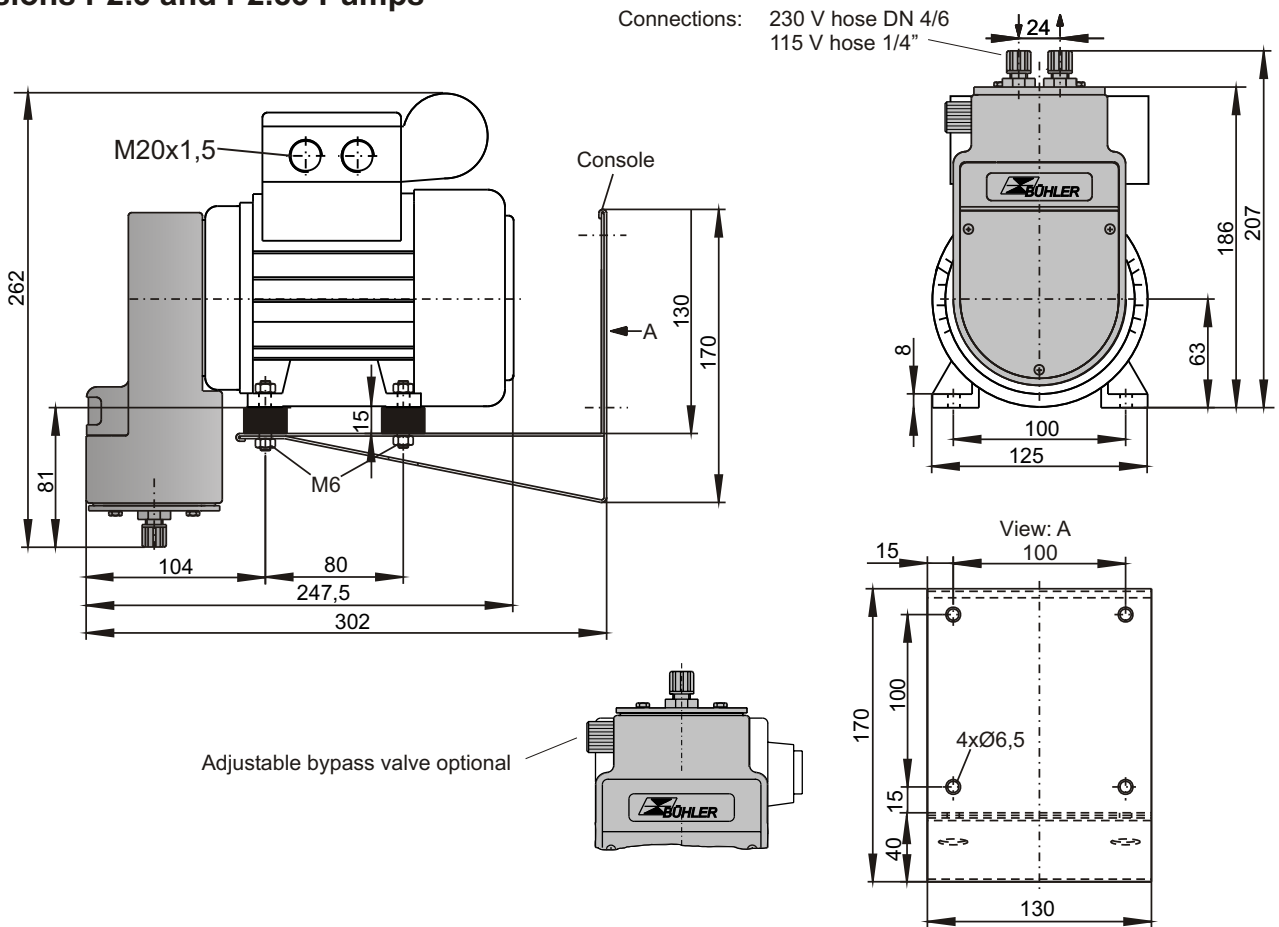

Dimensions P2.4 and P2.84 Pumps

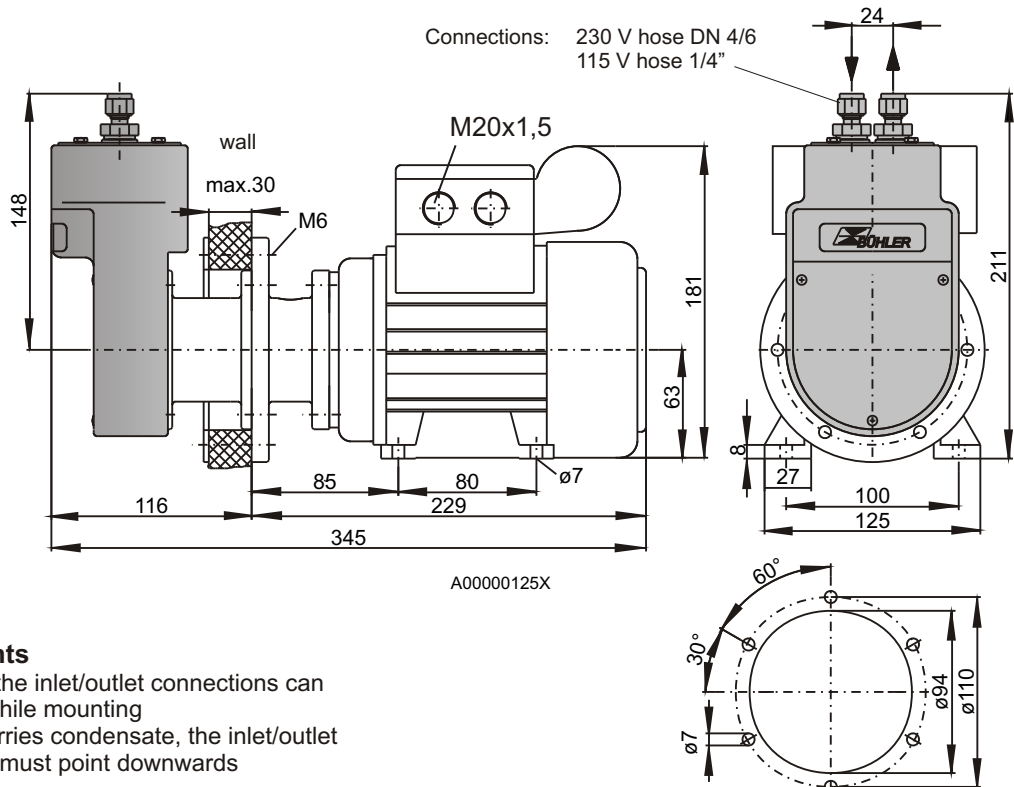

Mounting hints

- 1) Direction of the inlet/outlet connections can be chosen while mounting
- 2) If the gas carries condensate, the inlet/outlet connections must point downwards

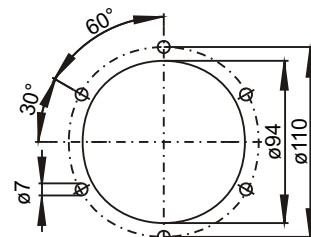

Cabinet cut-out