



OFFICIAL UK DISTRIBUTORS FOR:



DRM Technic

Suppliers of Gas Analysis Equipment

DSR25-ATEX
Peristaltic Drain Pump

DSR25-ATEX PERISTALTIC DRAIN PUMP

The DSR25 peristaltic pump has been designed for condensate removal, ensuring continuous condensate discharge in all gas analysis applications. The DSR25 has safe condensate removal, is reliable for continuous application, has no condensate flow back and is completely self-suctioning.

This datasheet is for the ATEX version of the pump which is suitable for hazardous conditions. A non-ATEX version is also available and has its own datasheet.



FEATURES

**Safe continuous condensate removal | Comes with return stop | Self-suctioning | Slow speed
Hose with long-service life | Explosion proof version according to ATEX for Zone 1**

SPECIFICATIONS

Product No.	DSR25-ATEX
Method of Mounting	Boxed typed
Protection / Electrical Standard	IP40; Ex II 2 G EEx m II T5 certificate no. KEMA 03ATEX2218 X
Electrical Connection	600 mm cable (4 x 0.5 mm ² with screwed cable gland M12 x 1.5)
Dimensions	130 x 110 x 80 mm (5.12" x 4.33" x 3.15")
Weight	0.7 kg (1.54 lb)
Peristaltic Pump Speed	5 rpm (standard)
Suction	200 mbar abs. (max.)
Pressure	2200 mbar abs. (max.)
Sample Temperature	0 °C to 60 °C (32 °F to 140 °F)
Ambient Temperature	5 °C to 50 °C (41 °F to 122 °F)
Storage Temperature	-10 °C to 60 °C (14 °F to 140 °C)
Connections	Tube connections DN 4/6mm
Material of sample contacting parts	PVDF, Novoprene
Power Supply / Consumption	115/230 V 50/60 Hz, 3.5 VA
Continuous Duty	100% ED

CONTACT US: DRM Technic, 15C Raleigh Hall Industrial Estate, Stafford, Staffordshire, ST21 6JL



OFFICIAL UK DISTRIBUTORS FOR:



DRM Technic

Suppliers of Gas Analysis Equipment

DSR25-ATEX
Peristaltic Drain Pump

TECHNICAL DRAWINGS

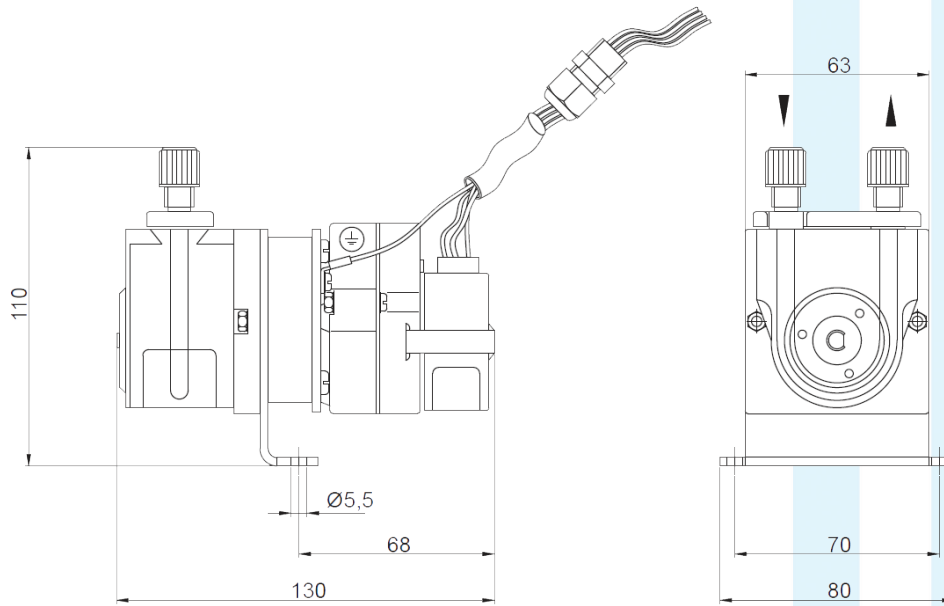

Dimensions in mm

PHOTOGRAPHS



Connecting box for 1 DSR25-ATEX pump



Connecting box for 4 DSR25-ATEX pumps

OPTIONS AND ACCESSORIES

Product No.	Description
DSR25	Peristaltic Drain Pump - Non-ATEX version (has own datasheet)
DRS25-ATEX-HS1	Connecting Box for one DRS25-ATEX pump Terminals (max.) 4 x 2.5mm ² / 1 x M20 x 1.5, 1 x M12 x 1.5; Electrical Standard: IP65, EX II 2 G EEx e II T5; Dimensions: 75 x 80 x 55 mm; Weight: 0.35 kg
DSR25-ATEX-HS4	Connecting Box for four DSR25-ATEX pumps Terminals (max.): 16 x 2.5 mm ² / 1 x M20 x 1.5, 4 x M12 x 1.5 Dimensions: 160 x 75 x 55 mm; Weight: 0.6 kg

CONTACT US: DRM Technic, 15C Raleigh Hall Industrial Estate, Stafford, Staffordshire, ST21 6JL