

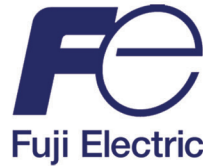

OFFICIAL UK DISTRIBUTORS FOR:



# DRM Technic

Suppliers of Gas Analysis Equipment

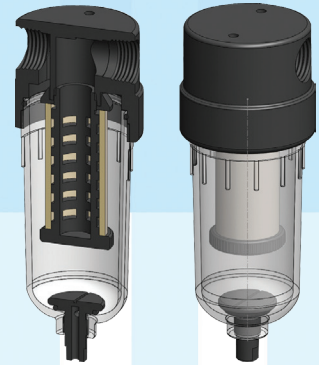

## FHx-AN ALUMINIUM / NYLON FILTER HOUSINGS

FHx-AN Filter Housings have an anodised aluminium head with nylon (polyamide) bowl and internals.

### FEATURES

Materials: Aluminium & Polymaide | Ports: 1/4" NPT (F) | Pressure: 10 Bar | Elements: See Specifications

### SPECIFICATIONS

Product No.	FH1-AN	FH2-AN	FH3-AN
<b>General</b>			
Port Size	1/4" NPT (F)	1/4" NPT (F)	1/4" NPT (F)
Drain	Manual	Manual	Manual
Max. Pressure	10 Bar	10 Bar	10 Bar
Max. Temperature	50 °C	50 °C	50 °C
<b>Materials of Construction</b>			
Head and Internals	Aluminium	Aluminium	Aluminium
Bowl	Polyamide	Polyamide	Polyamide
Seals	Viton	Viton	Viton
<b>Suitable Elements</b>			
Coalescing Filter Element	FH1-CFE	FH2-CFE	FH3-CFE
Particulate Filter Element	FH1-PFE	FH2-PFE	FH3-PFE
Adsorber Cartridge Code <sup>1</sup>	FH1-ATEX	FH2-ATEX	FH3-ATEX
<b>Principal Dimensions</b>			
Diameter	40 mm	62 mm	62 mm
Height	124.5 mm	171.5 mm	238 mm
Volume	25 cc	140 cc	240 cc
Weight	0.1 kg	0.3 kg	0.35 kg

### ACCESSORIES

Mounting Bracket	SMB	LMB	LMB
Fittings Kit	SFK	LFK	LFK
Catchpot Housing	--	FH2-AN-CP	--
Bubbler Housing	--	FH2-AN-BB	--
Float Housing	--	FH2-AN-F	--

CONTACT US: DRM Technic, 4 Cherry Orchard, Newcastle-under-Lyme, Staffordshire, UK, ST5 2UB

Tel: +44 (0) 1782 638491 | Email: sales@drmtechnic.com | Web: www.drmtechnic.com

DRM/FHXAN/  
121115/002

DRM/FHXAN/  
121115/002



OFFICIAL UK DISTRIBUTORS FOR:



# DRM Technic

Suppliers of Gas Analysis Equipment

## FHx-AN ALUMINIUM / NYLON FILTER HOUSINGS

### PARTS LIST <sup>1</sup>

Housing	FHx-AN
Filter Element	FHx-xFE
Adsorber Element	FHx-ATEx
Mounting Bracket	xMB
Fittings Kit	xFK

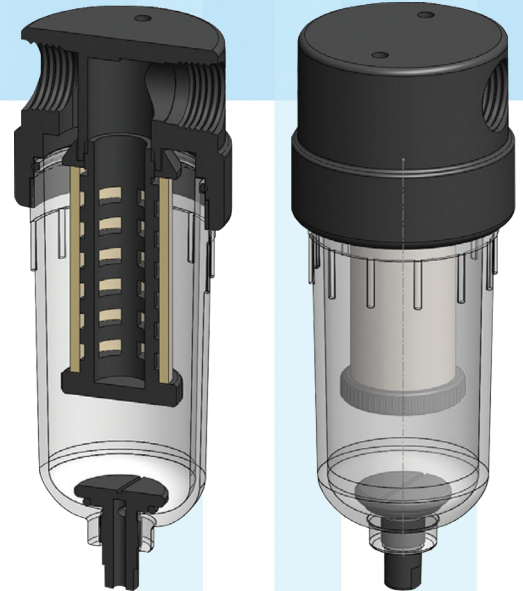

### FILTER GRADES

The efficiency depends on the flow rate and pressure but for analytical applications with typically low flows, you can consider:

Grade 5	Grade 6	Grade 7	Grade 8
0.1 Micron	1.0 Micron	10.0 Micron	+50.0 Micron
0.2 Micron	2.0 Micron	20.0 Micron	
	5.0 Micron		

### ADSORBER GRADES

Grade	Adsorber	Principal Uses
1	Activated Carbon Granules	Removal of hydrocarbons and other organic vapours
2	Activated Carbon Cloth	Removal of hydrocarbons and other organic vapours
3	Molecular Sieve 4A	Removal of CO <sub>2</sub> , NH <sub>3</sub> , H <sub>2</sub> S, and SO <sub>x</sub>
4	Molecular Sieve 13X	Removal of CO <sub>2</sub> , NH <sub>3</sub> , H <sub>2</sub> S, SO <sub>x</sub> , aromatics and amines
5	Silica Gel (Blue)	Removal of water vapour
5a	Silica Gel (Orange)	Removal of water vapour
6	Mixed Bases (Soda Lime)	Removal of acidic gases, CO <sub>2</sub> , SO <sub>x</sub> , NO <sub>x</sub> and HCl
7	Potassium Permanganate	Removal of SO <sub>x</sub> and other acidic gases
8	Hopcalite	Removal of CO by catalytic conversions to CO <sub>2</sub>

**FOOTNOTES:** <sup>1</sup> Replace "x" with the grade of adsorber required; ie. FH1-ATE3. For more details on the grades available, see the adsorber grade box above.

CONTACT US: DRM Technic, 4 Cherry Orchard, Newcastle-under-Lyme, Staffordshire, UK, ST5 2UB

Tel: +44 (0) 1782 638491 | Email: sales@drmtechnic.com | Web: www.drmtechnic.com

DRM/FHXAN/  
121115/002

DRM/FHXAN/  
121115/002