

Sample Gas Cooler EGK 2 Ex



Accurate measurements of gases require gas samples with stable dew points even under harsh ambient conditions.

The EGK models provide a CFC-free, compressor-type cooling system connected to a cooling block. The cooling block evenly dissipates the heat thus supporting the highly efficient heat exchangers. The temperature of the cooling block is regulated by the **Bühler Constant Regulating System**. This system allows smooth regulation and eliminates the disadvantages of the traditional on-off operating mode.

The controller is self-checking. Significant deviation from the preset is signalled by a status output. A bi-color LED on the front shows 4 different operating conditions.

Condensate is removed either into condensate vessels or by automatic condensate drainers which can be attached to the heat exchangers within the cooler's outer contour.

- **ATEX certificate Zone 1 (Cat. 2G)**
- **CFC-free**
- **Nominal cooling capacity 615 kJ/h**
- **1 or 2 heat exchangers can be inserted: up to 4 gas paths**
- **Self-checking with status output**
- **4 operational conditions displayed**
- **Simple operation and test**
- **Easy to install**
- **Condensate draining can be mounted inside of outer shape**

Technical Data

ATEX-class	Ⓔ II 2 G Ex px e mb q [ia] IIC T4 Gb
Ready for operation	after max. 20 minutes
Cooling capacity (at 25 °C)	> 615 kJ/h (170 W)
Ambient temperature	0 °C to 45 °C
Gas outlet dewpoint (preset)	approx. 5 °C
Dew point stability static	± 0.2 K (with st. steel) ± 0.5 K (with PVDF)
Over whole spec. Range:	± 2 K
Power supply	230 V, 50 Hz or 115 V, 60 Hz
Power consumption	250 VA (230 V) 300 VA (115 V)
Fuse	motor protection switch
Potential-free status outputs (fail-safe)	250 V / 3 A AC 24 V / 1 A DC
Protection class electrically	IP 54
Housing material	stainless steel / polyester
Installation	upright or against wall
Dimensions (H x W x D)	approx. 700 mm x 500 mm x 500 mm
Weight incl. 2 heat exchangers	approx. 37 kg

Display

Status LED with 4 conditions:

Green:	Temperature in range
Green flashing:	Temperature in range, compressor is running
Red:	Temperature off range, cooling operation
Red flashing:	Cooler stopped or service required

Dimensions (mm)

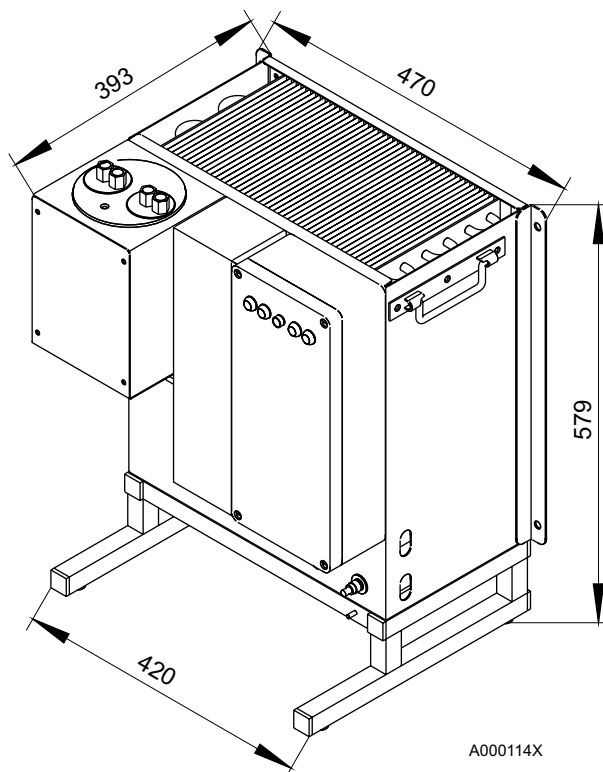

Heat Exchanger

The energy content of the sample gas and, as a result, the required cooling capacity of the gas cooler is determined by 3 parameters: gas temperature ϑ_G , dewpoint τ_e (moisture content) and flow v . The outlet dew point rises with increasing energy content (heat) of the gas. The required cooling capacity is determined by the maximum acceptable level of the outlet dew point.

The following table shows cooler performance assuming the following conditions: $\tau_e=65^\circ\text{C}$ and $\vartheta_G=90^\circ\text{C}$. Indicated is the v_{max} in l/h cooled air (i.e. after the moisture has condensed). If the actual values stay below the parameters τ_e and ϑ_G , v_{max} can be increased. For example (TG), instead of $\tau_e=65^\circ\text{C}$, $\vartheta_G=90^\circ\text{C}$ and $v=250$ l/h the values $\tau_e=50^\circ\text{C}$, $\vartheta_G=80^\circ\text{C}$ and $v=350$ l/h could be achieved.

Please contact one of Buhler's application specialists for assistance and further information.

Heat Exchanger	TS	TG	TV	DTS	DTG	DTV ⁴⁾
Flow rate v_{max} ¹⁾	530 l/h	280 l/h	125 l/h	2*250 l/h	2*140 l/h	2*115 l/h
Inlet dewpoint $\tau_{e,\text{max}}$ ¹⁾	80 °C	80 °C	65 °C	80 °C	65 °C	65 °C
Gas inlet temperature $\vartheta_{G,\text{max}}$ ¹⁾³⁾	180(135) °C	135°C	135 °C	180(135) °C	135 °C	135 °C
Max. cooling capacity Q_{max}	450 kJ/h	230 kJ/h	120 kJ/h	450 kJ/h	230 kJ/h	185 kJ/h
Gas pressure p_{max}	160 bar	3 bar	3 bar	25 bar	3 bar	2 bar
Pressure drop Δp ($v=150$ l/h)	8 mbar	8 mbar	8 mbar	each 5 mbar	each 5 mbar	each 15 mbar
Dead volume V_{tot}	69 ml	48 ml	129 ml	28/25 ml	25/25 ml	each 21 ml
Sample gas connections	G 1/4" i ²⁾	GL 14	DN 4/6	tube 6mm	GL 14	DN 4/6
Condensate out connections	G 3/8" i ²⁾	GL 25	G 3/8" i	tube 10mm	GI184	DN 5/8

¹⁾ With maximum heat transfer of the heat exchanger and max. cooling capacity of the cooler

²⁾ NPT-threads upon request

³⁾ Values in parentheses due to temperature class

⁴⁾ Use of automatic condensate drainers and glass vessels not possible

Performance Data

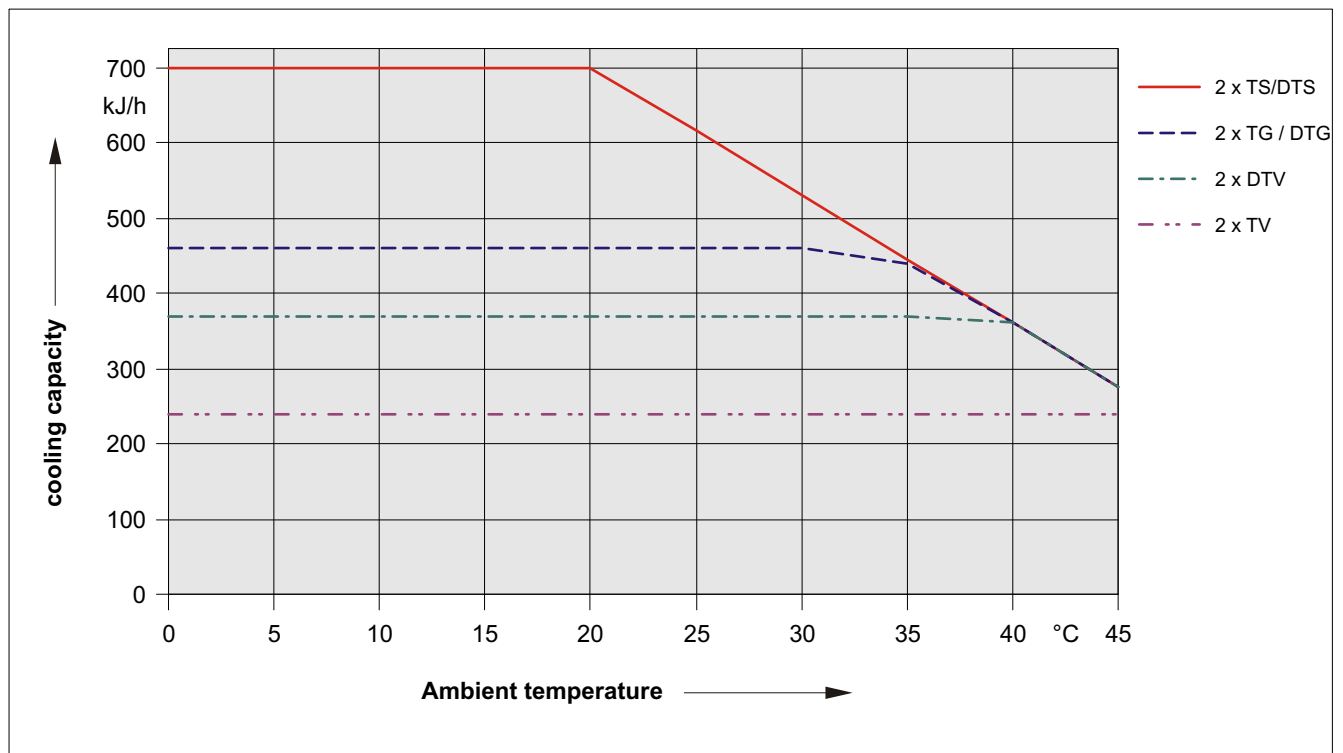

Please indicate with order

Please extract the part number for the cooler fulfilling your requirements from the type code below.

Please note: Each gas path should be equipped with a peristaltic pump or an automatic condensate drain.

Part No.	4	5	9	0					0	0	0	EGK 2Ex
Power Supply¹⁾												
	1											115 V
	2											230 V
Gas Path / Material / Version												
	0	0	0									Without heat exchanger
1 Gas Path / Material / Version												
	1	1	0									1 single path heat exchanger / stainless steel / TS
	1	2	0									1 single path heat exchanger / glass / TG
	1	3	0									1 single path heat exchanger / PVDF / TV-SS
2 Gas Paths / Material / Version												
	2	1	0									2 single path heat exchangers / stainless steel / TS
	2	2	0									2 single path heat exchangers / glass / TG
	2	3	0									2 single path heat exchangers / PVDF / TV-SS
	2	6	0									1 dual path heat exchanger / stainless steel / DTS
	2	7	0									1 dual path heat exchanger / glass / DTG
	2	8	0									1 dual path heat exchanger / PVDF / DTV ²⁾
3 Gas Paths / Material / Version												
	3	1	0									1 single path + 1 dual path heat exchanger / stainless steel / TS+DTS
	3	2	0									1 single path + 1 dual path heat exchanger / glass / TG+DTG
	3	3	0									1 single path + 1 dual path heat exchanger / PVDF / TV-SS+DTV ²⁾
4 Gas Paths / Material / Version												
	4	6	0									2 dual path heat exchangers / stainless steel / DTS
	4	7	0									2 dual path heat exchangers / glass / TG
	4	8	0									2 dual path heat exchangers / PVDF / DTV ²⁾
Condensate Discharge												
											0	Without condensate discharge
											3	AK20 assembled
											4	11 LD V38 assembled

¹⁾ Operating the cooler in the hazardous area is allowed only with sufficient motor protector switch.

²⁾ Automatic condensate drains or condensate vessel cannot be connected.

Accessories

91 320 200 09	Motor protection switch mounted outside of hazardous area for cooler 230V/50Hz
91 320 200 29	Motor protection switch mounted outside of hazardous area for cooler 115V/60Hz
91 320 200 32	Motor protection switch mounted inside of hazardous area for cooler 230V/50Hz
91 320 200 35	Motor protection switch mounted inside of hazardous area for cooler 115V/60Hz
44 100 05	Condensate vessel GL 1; glass, 0,4 l
44 100 19	Condensate vessel GL 2; glass, 1 l