



OFFICIAL UK DISTRIBUTORS FOR:



DRM Technic

Suppliers of Gas Analysis Equipment

DRM ABS60 SO3 ABSORBER

The DRM ABS60 SO3 Absorber is used to remove aggressive components (SO3, etc) from sample gases in emissions/process monitoring applications. Components such as CO, O2, CO2, NOx, SO2, etc, are not usually affected by the reactive material.

The absorber is fitted before the analyser, ideally immediately before a DRM WS60 waterstop filter. It should be installed in a vertical position, not horizontal. It can be fixed to a back plate with 2 heavy duty clamps.



FEATURES

Refillable | Simple maintenance | Replaceable parts

SPECIFICATIONS

Size (Max.)	55mm x 260mm
Gas Inlet/Outlet	PVDF fittings for 6/4 mm tubing
Material	Glass / Filter Wool / Absorber Materials (C/Z)
Material Lifespan	Dependent on sample gas concentration
Max. Temperature	40 °C
Fixing Method	2x Clamps

OPTIONS AND ACCESSORIES

Product No.	Description
Replacement Absorber Material	ABS60-M
Replacement Fittings	ABS60-F
Replacement Red Cap	ABS60-RC
Replacement Glass Tube	ABS60-G
Replacement Fixing Clamp	ABS60-C

TECHNICAL DRAWINGS

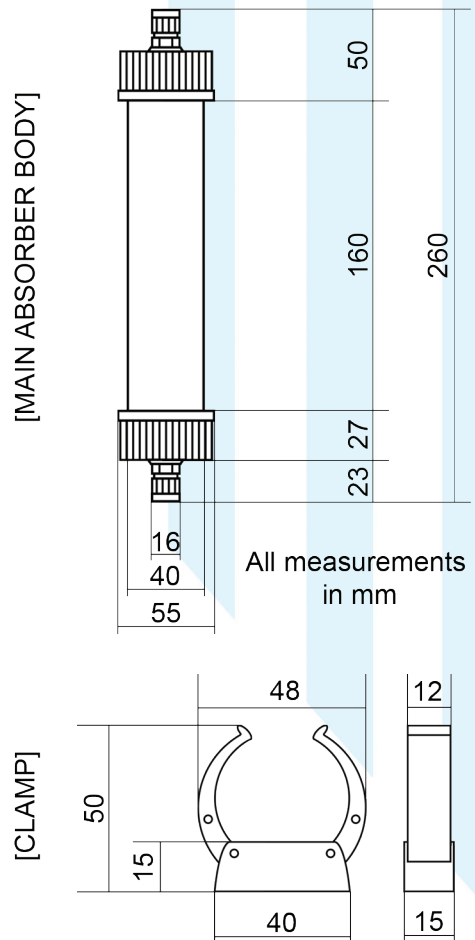

CONTACT US: DRM Technic, 4 Cherry Orchard, Newcastle-under-Lyme, Staffordshire, UK, ST5 2UB

Tel: +44 (0) 1782 638491 | Email: sales@drmtechnic.com | Web: www.drmtechnic.com

DRM/ABS03/
151015/001